



# Frac Pump Parts

## 12x10 Dominator – Discharge Pump

### EFFICIENCY

The Dominator's high-end efficiency and performance, even at lower RPMs, reduce our customer's engine wear, fuel costs and carbon footprint all at once.

### ENCLOSED IMPELLER

The Dominator's enclosed impeller allows for customers to safely and effectively operate with additives.

### HIGH CHROME

All parts on the Dominator are uniformly designed to have industry leading hardness and strength.

### 24/7/365 SERVICE

Our customers are our main priority, and we pride ourselves on the customer service levels we provide.

For more information on the Dominator or any of our other pumps, feel free to contact us:

www.fracpumpparts.com  
 sales@fracpumpparts.com  
 (775)-55-PUMPS



- Hydraulically Efficient
- Enclosed Impeller
- Reduces Engine Wear, Fuel Usage and Carbon Footprint
- 5000 lbs. Total Weight

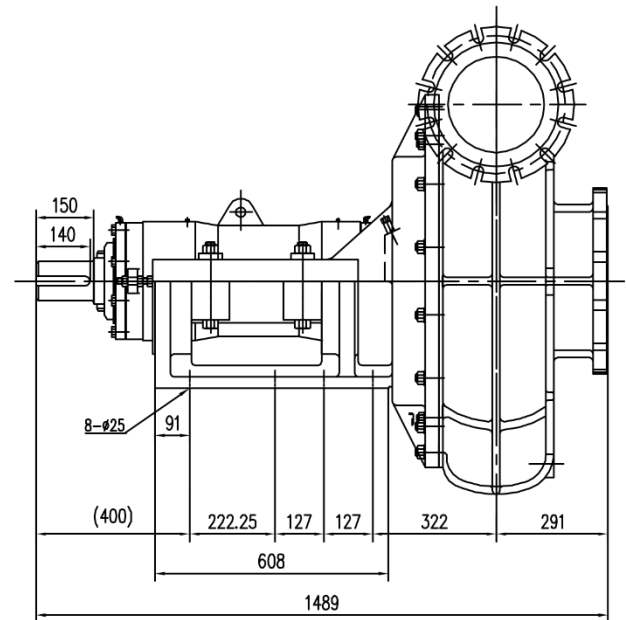
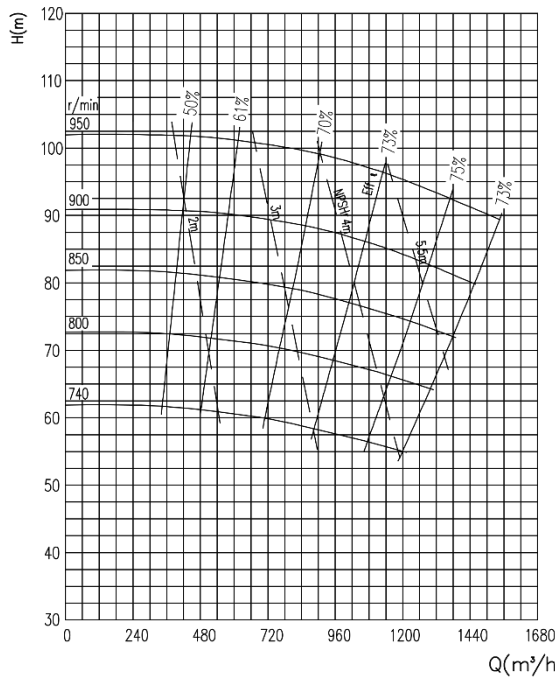

Shaft Dimension

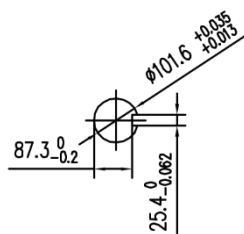

Discharge Flange

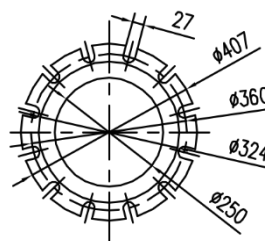

Suction Flange

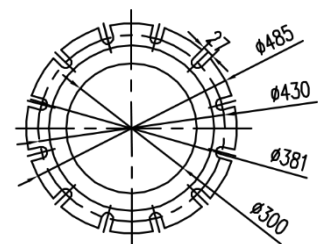

**Frac Pump Parts**

sales@fracpumpparts.com | (775)-55-PUMPS